



HiVi

High performance speaker from

Hear The Difference

## 惠威车用超低音扬声器

HI-END CAR LOUDSPEAKER SYSTEM

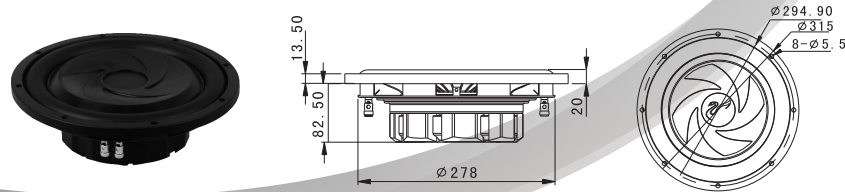

a、感谢阁下购买惠威车用超低音扬声器，在愉快的驾驶中享受惠威科技给予构建的音乐氛围，秉承惠威一贯的Hi-End理念，声音准确，音色圆润，声场宽阔，低音强劲，加上毫无保留的细节重现，让你感受真正车载音乐的体验。

b、PS系列超低音扬声器采用电声科技超薄形设计，在能够获得理想低频效果的同时，更少的占用车内宝贵的空间，达到音效与空间的相互结合，振膜采用高分子复合声学专用材质和特殊纤维复合而成，声学工艺的结构设计，使低音更有质感，还原更出色。

c、为了便于您的安装及使用，我们编写本手册。

d、虽然这本手册说明了安装的方式，但是对于汽车拆装并没有作说明，假如您没有此方面的经验，请不要自行安装，您可以去有经验的汽车服务处进行咨询。

e、根据不同型号的扬声器系统，我们推荐使用不同的箱体类型。

请特别注意您的汽车处于熄火状态!

### 规格参数

额定阻抗	4Ω+4Ω
音圈直径	50mm
谐振频率	33Hz
机械Q值	5.01
电Q值	0.80
总Q值	0.69
顺性	66.4 μm/N
等效容积	24.2L
振动质量	340g
灵敏度	86dB/1W/1M
额定功率	300W
最大功率	600W
适合箱体类型	封闭箱

使用箱体类型:

#### 1.小箱体

Ps12: 推荐箱体净容积:14L  
F3: 49Hz  
Qtc: 0.873

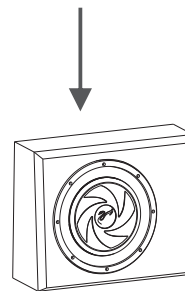

#### 2.大箱体

Ps12: 推荐箱体净容积:22L  
F3: 44.8Hz  
Qtc: 0.785

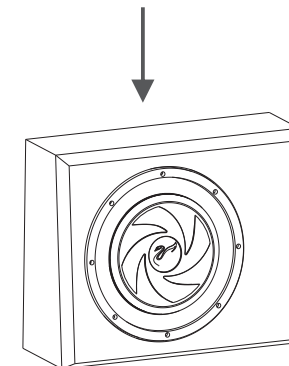

注:非常感谢阁下的惠顾,在箱体内容积满足参考值的情况下,可根据实际车身尺寸改变箱体外型,不影响声频重放,请阁下放心使用。



**HiVi**

High performance speaker from

*Hear The Difference*

**HI-END CAR LOUDSPEAKER SYSTEM**

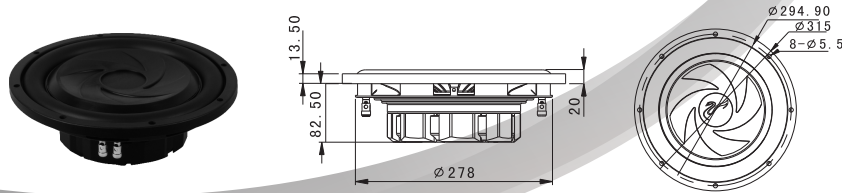

Thanks for your purchase of HiVi Hi-end car audio speakers, enjoying the music ambience with HiVi technology during your pleasure driving! Taking the persistent concept of HiVi, accurate sound, smooth tamber, wise sound field, adding the detail recur of no remain sound, will give you the real music.

PS Series subwoofers super book-shaped design, rich low frequency, save more space, make space and sound perfect combination. The cone used polypropylene to strengthen shaped design, which make the voice cleaner and more perfect. pls refer our user menu to install our speakers.

In order to facility your equipment and usage, we compile this brochure!

We suggest using various style boxes to cooperate different speaker systems! Although this brochure illustrate the mounting way, but no explanations for the car dismantle, supposing that you did not have such experiences, pls don't install by yourself, you can inquire the experienced car service station.

Pls pay more attention that your car must be flameout!

Please note specially your automobile must be placed in flameout state!

### Technical parameter:

Impedence	4 Ω + 4 Ω
Voice coil diameter	50mm
Resonance frequency	33Hz
Mechanical Q factor	5.01
Electrical Q factor	0.80
Total Q factor	0.69
Suspension compliance	66.4 μ m/N
Equivalent cas air load	24.2L
Effective moving mass	340g
Sensitivity	86dB/1W/1M
Power handling	300W
Max power	600W
Comfortable box style	Phase-reversal box

### Box style:

Sm allbox 14L iters  
F<sub>3</sub>:49Hz  
Qtc:0.873

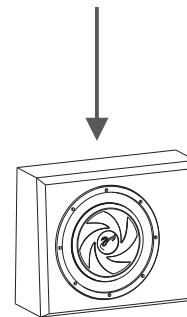

Big box 22L iters  
F<sub>3</sub>:44.8Hz  
Qtc:0.785

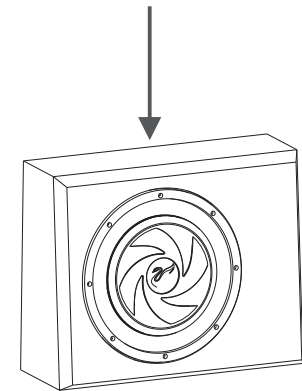

Attention: thanks very much for your purchasing. When accord with thereference factor of the box, you can change the box appearanceaccording to your factual car dimension, this will not affect